



KILLARK®

INSTALLATION, OPERATION & MAINTENANCE DATA SHEET

FIELD INSTALLATION OF HINGE-12L (LEFT SIDE), HINGE-12R (RIGHT SIDE) EXTRUDED ALUMINUM HINGES FOR ELECTRICAL ENCLOSURE



**HINGE-12L
(LEFT)**



**HINGE-12R
(RIGHT)**

FIELD INSTALLATION OF HINGE-12L, HINGE-12R

CAUTION:

Before installing, make sure you are compliant with area classifications, failure to do so may result in bodily injury, death and property damage. Do not attempt installation until you are familiar with the following procedures. All installation must comply with the applicable Electrical Code.

Make sure that the circuit is de-energized before starting installation or maintenance.

Verify that the installation is grounded. Failure to ground will create electrical shock hazards, which can cause serious injury or death.

IMPORTANT:

Please read these instructions carefully before installing or maintaining this equipment. Good electrical practices should be followed at all times and this data should be used as a guide only.

Technical information, advice and recommendations contained in these documents is based upon information that Killark believes to be reliable. All the information and advice contained in these documents is intended for use only by persons having been trained and possessing the requisite skill and know-how and to be used by such persons only at their own discretion and risk. The nature of these instructions is informative only and does not cover all of the details, variations or combinations in which this equipment may be used, its storage, delivery, installation, check out, safe operation and maintenance. Since conditions of use of the product are outside of the care, custody and control of Killark, the purchaser should determine the suitability of the product for his intended use, and assumes all risk and liability whatsoever in connection therewith.



3940 Dr. Martin Luther King Drive
St. Louis, MO 63113

P/N KIL00921459 FORM NO. K1459 ERO-2-056-15

Page 1 of 3

1. DIRECTIONS FOR INSTALLATION (HINGE-12L)

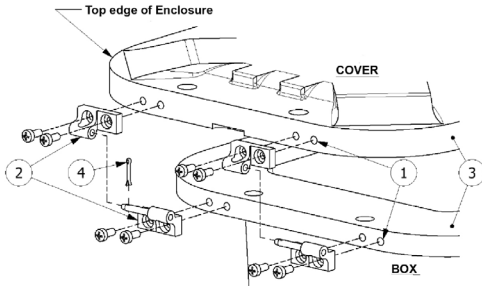

Figure 1. Exploded assm. of encl. & hinges

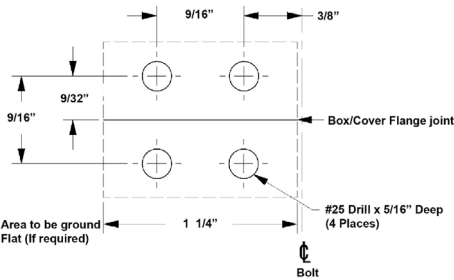

Figure 2. Top (upper) hinge drawing

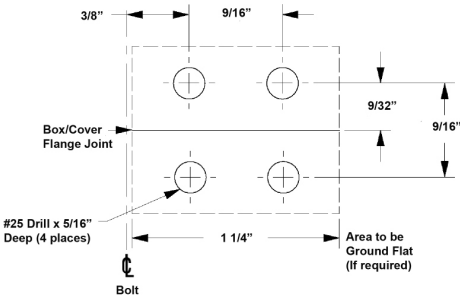

Figure 3. Bottom (lower) hinge drawing

- When replacing an existing Hinge-9L, use the existing mounting holes, but, use the new hardware supplied with the new hinge. If the existing mounting hole threads are stripped out, it will be necessary to relocate the hinge and drill new mounting holes. It is recommended that a #25 (.149" dia.) drill be used for the self-tapping, thread forming screws supplied.
- For new installations, or when relocating a hinge, be sure the box and cover are assembled and secured by at least 2 bolts (one at each end of the enclosure) to properly align the bolt holes. On some enclosures, it may be necessary to grind the flange area to provide a flat, even surface for the hinges. Hinge-12L assemblies are to be located off of the first and last bolt holes on left side of the enclosure.
- Using the drawings and dimensions on the page as a guide, locate and center punch the mounting hole locations on the flange and then drill as indicated (Item 1).
- Unbolt the cover from the box and install the hinge components to the box and cover as shown below, using the screws provided (Item 2).
- When all hinge components are in place and tight, the cover can be re-attached to the box. When assembling the cover to box, the top Hinge-12L half will start to slide over its hinge pin before the bottom Hinge-12L slides over its pin. Do not allow the cover flange to be seated on the box flange while sliding the hinge assemblies together (Item 3).
- Install the cotter pin in the top hinge pin and test the operation of the hinges prior to bolting the cover to box (Item 4). Trim excess cotter pin tangs to desired length as needed.
- NOTE:** Hinges should be lubricated periodically with a light oil to prevent binding, and should be inspected regularly for damage. If a hinge is damaged, the entire hinge assembly must be replaced.

1. DIRECTIONS FOR INSTALLATION (HINGE-12R)

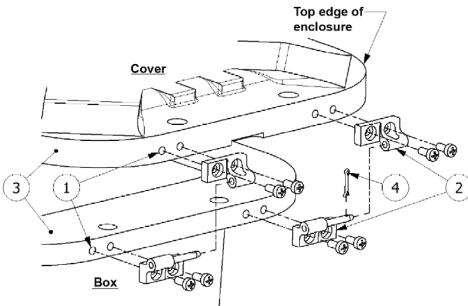

Figure 1. Exploded assm. of encl. & hinges

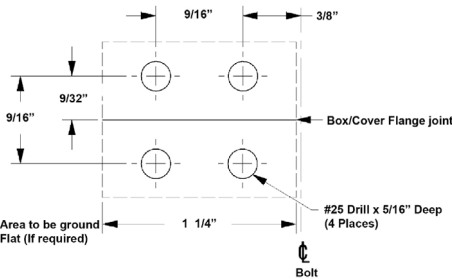

Figure 2. Top (upper) hinge drawing

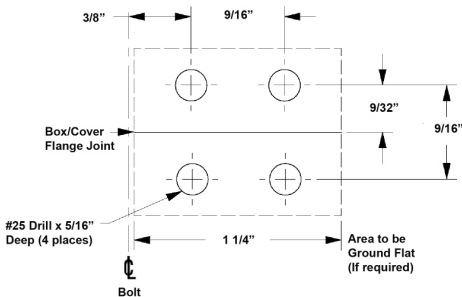

Figure 3. Bottom (lower) hinge drawing

1. When replacing an existing Hinge-9R, use the existing mounting holes, but, use the new hardware supplied with the new hinge. If the existing mounting hole threads are stripped out, it will be necessary to relocate the hinge and drill new mounting holes. It is recommended that a #25 (.149" dia.) drill be used for the self-tapping, thread forming screws supplied.
2. For new installations, or when relocating a hinge, be sure the box and cover are assembled and secured by at least 2 bolts (one at each end of the enclosure) to properly align the bolt holes. On some enclosures, it may be necessary to grind the flange area to provide a flat, even surface for the hinges. Hinge-12R assemblies are to be located off of the first and last bolt holes on left side of the enclosure.
3. Using the drawings and dimensions on the page as a guide, locate and center punch the mounting hole locations on the flange and then drill as indicated (Item 1).
4. Unbolt the cover from the box and install the hinge components to the box and cover as shown below, using the screws provided (Item 2).
5. When all hinge components are in place and tight, the cover can be re-attached to the box. When assembling the cover to box, the top Hinge-12R half will start to slide over its hinge pin before the bottom Hinge-12R slides over its pin. Do not allow the cover flange to be seated on the box flange while sliding the hinge assemblies together (Item 3).
6. Install the cotter pin in the top hinge pin and test the operation of the hinges prior to bolting the cover to box (Item 4). Trim excess cotter pin tangs to desired length as needed.
7. **NOTE:** Hinges should be lubricated periodically with a light oil to prevent binding, and should be inspected regularly for damage. If a hinge is damaged, the entire hinge assembly must be replaced.